



Parts Manual
X17 ECO EXTRACTOR

For Safety When Servicing or Maintaining Machine

- Stop on level surface.
- Disconnect the power to the machine.
- Avoid moving parts. Do not wear loose jackets, shirts, or sleeves when working on machine.
- When working around machine use protective clothing and safety glasses. Remove metal jewelry.
- Do not clean machine with a pressure washer.
- Authorized personnel must perform repairs and maintenance. Use Minuteman supplied replacement parts.

Table of Contents

X17 ECO Extractor Main Assembly I Rear View.....	1
X17 ECO Extractor Main Assembly BOM	2
Solution Tank Assembly Front View	3
Solution Tank Assembly Rear View	4
Solution Tank Assembly BOM	5
Recovery Tank Assembly	6
Recovery Tank Assembly BOM	7
Recovery Dome Lid Assembly	8
Spray Bar Assembly, X17	9
X17 ECO Handle Assembly	10
X17 ECO Handle Assembly BOM.....	11
X17 ECO Handle Assembly Breakout	12
Back Panel Assembly	13
Chassis Sub-Assembly X17-ECO	14
Chassis Sub-Assembly X17-ECO BOM	15
Brush Head Assembly ECO	16
Brush Head Assembly ECO BOM	17
Valve-Filter Assembly, X17	18
Wiring Schematic 115V, Handle Assembly X17-ECO	19
Wiring Schematic 115V, Wire Harness X17-ECO	20
X17-ECO 115V Electrical Schematic Reference Numbers	21
Wiring Schematic 230V, Handle Assembly X17-ECO	22
Wiring Schematic 230V, Wire Harness X17-ECO.....	23
X17-ECO 230V Electrical Schematic Reference Numbers	24

X17 ECO Extractor Main Assembly I Rear View

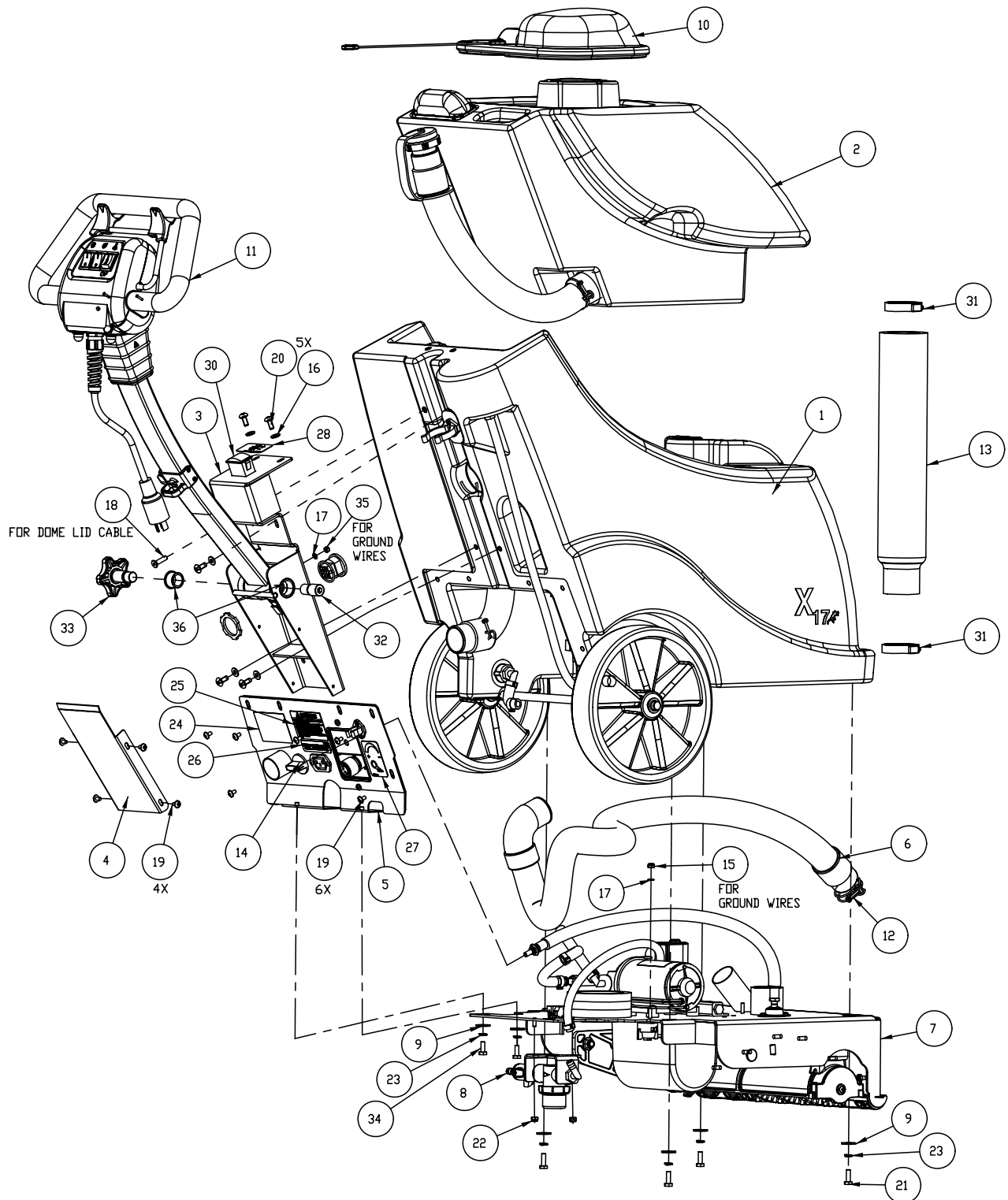

X17 ECO Extractor Main Assembly BOM

BILL OF MATERIAL - X17115 / X17230 / X17115HP / X17230HP				
ITEM	PART NO.	REQ'D	DESCRIPTION	NOTES
1	173010	1	SOLUTION TANK EX17-ECO ASSEMBLY	115V MODELS ONLY
1A	173010-230	1	SOLUTION TANK EX17-ECO ASSEMBLY	230V MODELS ONLY
2	173020	1	RECOVERY TANK EX17-ECO ASSEMBLY	
3	173035	1	HANDLE BRACKET -WELDMENT	
4	173036	1	REAR PANEL COVER	
5	173043	1	BACK PANEL ASSEMBLY	
6	173044	1	HOSE, CLEAR VAC	
7	173050	1	EX17-ECO CHASSIS ASSEMBLY	X17115 ONLY
7A	173050-230	1	EX17-ECO CHASSIS ASSEMBLY	X17230 ONLY
7B	173050HP	1	EX17-ECO CHASSIS ASSEMBLY	X17115HP ONLY
7C	173050-230HP	1	EX17-ECO CHASSIS ASSEMBLY	X17230HP ONLY
8	173058	1	VALVE-FILTER ASSEMBLY	
9	173080	6	WSR-FLT 17/64 x 7/8 x 0.07 SS	
10	173195	1	DOME LID ASSY, X17	AFTER 08/2011 - S/N: 11080350
	173027	1	DOME LID ASSY, X17	NLA - REPLACE WITH K-DOMELID
11	173200	1	X17 HANDLE ASSEMBLY-115V - UL	115V MODELS ONLY
11A	173201	1	X17 HANDLE ASSEMBLY - 230V	230V MODELS ONLY
12	172329	1	WIRE GRIP HOSE CLAMP	
13	320836	1	MUFFLER, VAC MOTOR	
14	452029	1	KNOB 1520X BLK 1/4BRAS	
15	711350	1	NUT-NYLOC 10-32	115V MODELS ONLY
15A	711350	2	NUT-NYLOC 10-32	230V MODELS ONLY
16	711504	5	WSR-FLAT 1/4 ID SS	
17	711553	2	WSR- INTERNAL LOCK #10	115V MODELS ONLY
17A	711553	3	WSR- INTERNAL LOCK #10	230V MODELS ONLY
18	712153	1	SC-SHCS, 1/4-20 x 1.00 IN SS	
19	712540	10	SCR-MC TR HD 10-24 X .37 SS	
20	712559	5	SCR-TR 1/4-20 X .62 TORX TR HD	
21	712562	4	BOLT-HH 1/4-20X3/4 SS	
22	712638	2	NUT, HEX 10-24 SS NYLOC	
23	712758	6	WSR-HELICAL 1/4 SS	
24	715047	1	DECAL-CLEAR LAMINATE 2X3	
25	715061	1	GENERAL WARNING DECAL	
26	715340	1	DECAL-USE W/ C46300-00 ONLY	115V MODELS ONLY
26A	715340-1	1	DECAL-USE W/ C46300-02 ONLY	230V MODELS ONLY
27	715725	1	DECAL, BRUSH PRESSURE & AUX OUT	
28	715726	1	DECAL, AMPERMETER	
29	715950	1	LABEL, PATENT NUMBERS	
30	748671	1	GAUGE, BRUSH PRESSURE X17	
31	760859	2	CLAMP, HOSE	
32	931045	1	HEX SOC. HEAD PIN	
33	931753	1	KNOB-HANDLE	
34	11038072	2	BLT-HH M6-1.0 x 16 STL ZINC	
35	12040036	1	NUT-NYLOC M5 X 0.8	
36	553130054	2	BUSH LH&RH-PILLER HANDLE	
37	748613	1	CORD, 14/3 SJTW 50' PANTONE 430	115V MODELS ONLY (NOT SHOWN)
37A	748613CE	1	CORD POWER CE 16A/250VAC H05VVF3G1.5 50F	230V MODELS ONLY (NOT SHOWN)

Solution Tank Assembly Front View

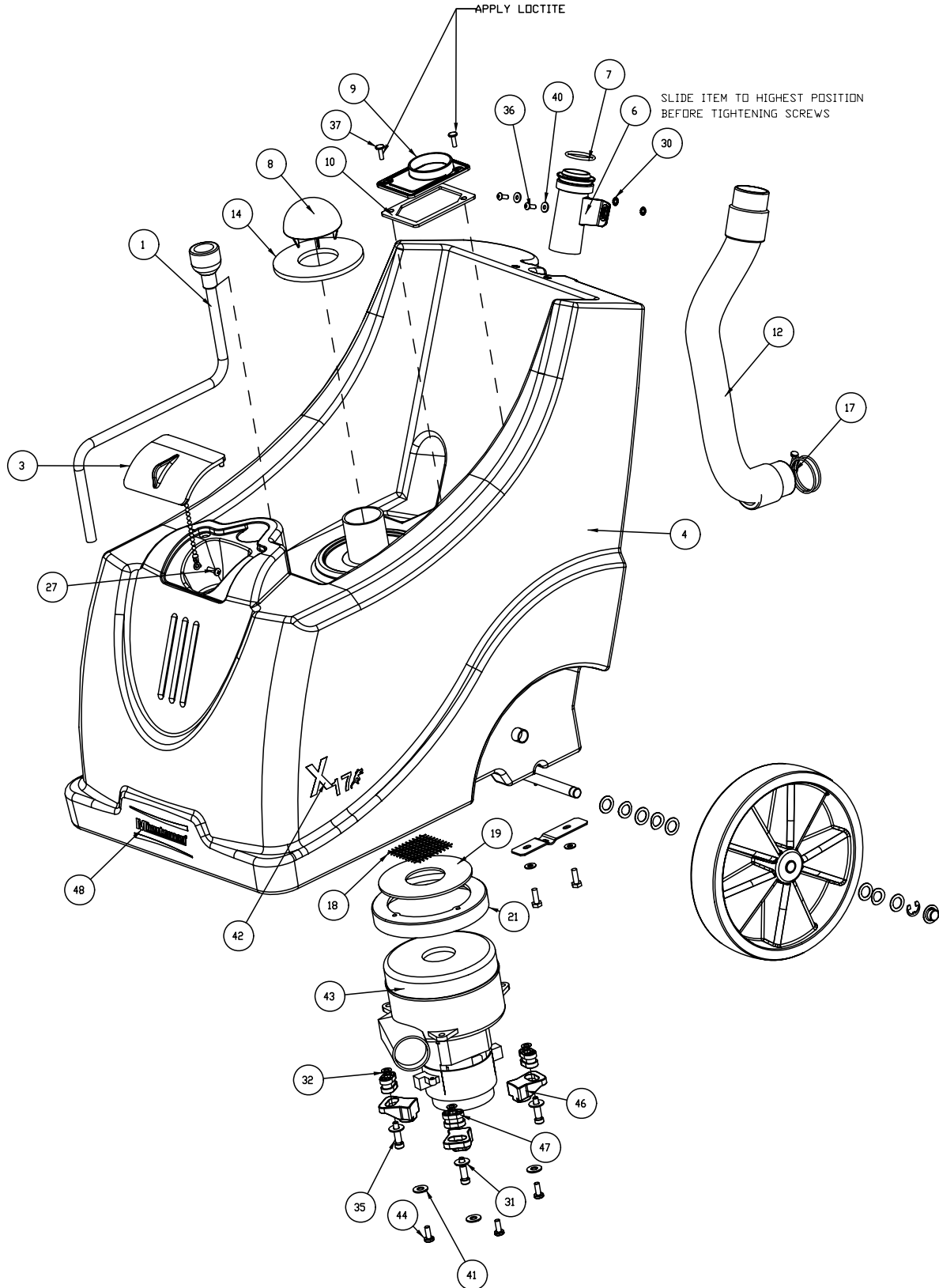

Solution Tank Assembly Rear View

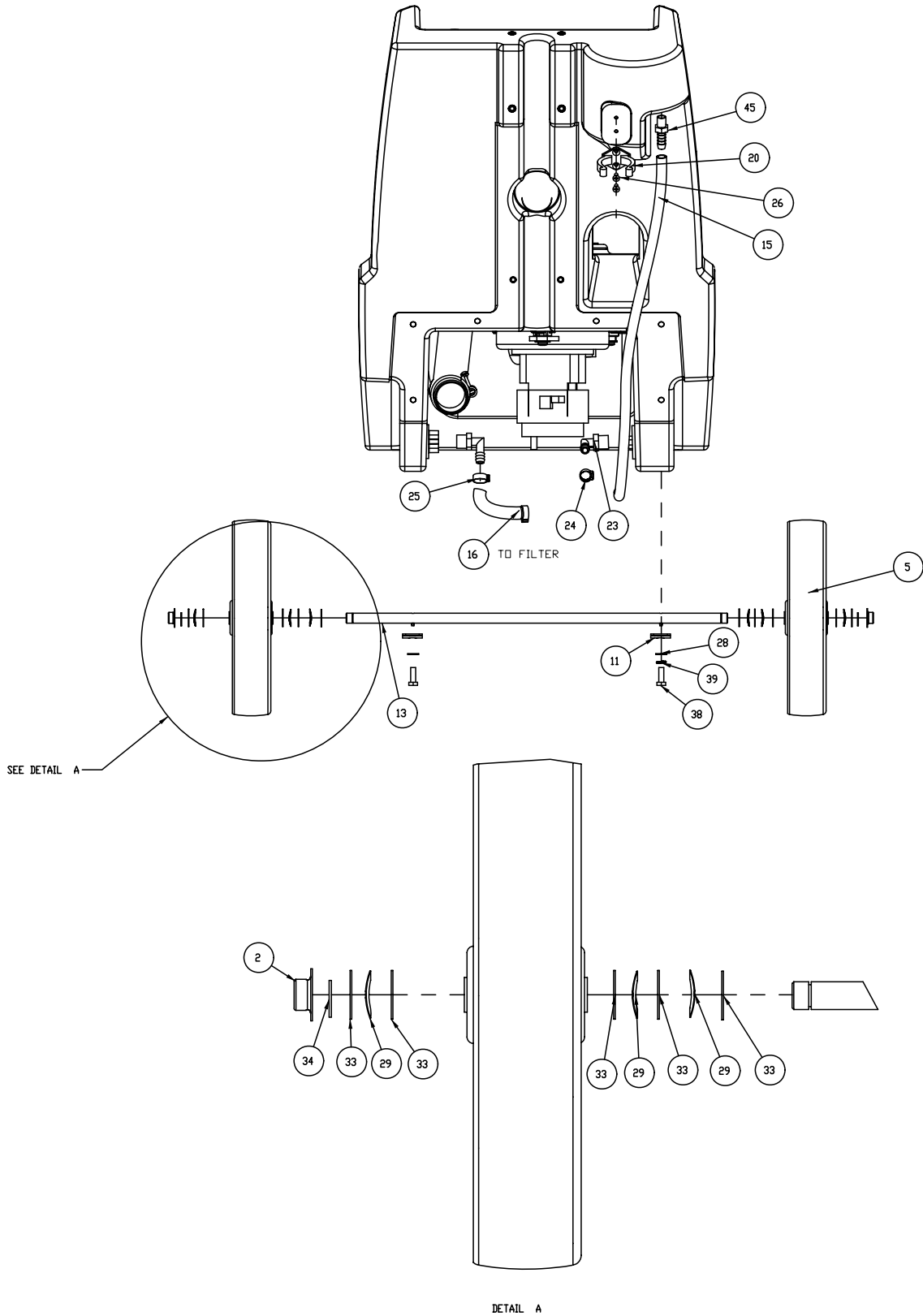

Solution Tank Assembly BOM

BILL OF MATERIAL -173010 / 173010-230				
ITEM	PART NO.	REQ'D	DESCRIPTION	NOTES
1	121082	1	FAUCET FILL HOSE ASSY	
2	130032	2	WHEEL RETAINER CAP	
3	172018	1	SOLUTION TANK LID ASSY	
4	173001	1	SOLUTION TANK EX17-ECO	
5	173005	2	WHEEL 10"	
6	173011	1	RECOVERY INLET ASSY	
7	173012	1	O-Ring, 1.234 ID x 1.512 OD, SIZE 218	
8	173013	1	AIR INLET UMBRELLA	
9	173014	1	HOSE CONDUIT	
10	173015	1	GASKET, HOSE CONDUIT	
11	173019	2	AXLE BRACKET	
12	173046	1	HOSE, RECOVERY	
13	173074	1	AXLE, WHEEL X17 ASSEMBLY	
14	173106	1	GASKET	
15	173152	1	WATER LINE GAUGE 3/8 I.D x 22 IN	
16	173157	1	HOSE, 3/8 ID X 4 IN	
17	260203	1	WIRE GRIP HOSE CLAMP	
18	260212	1	SCREEN FILTER	
19	260294	1	GASKET 260	
20	260579	1	TOOL CLIP, 1.5" HOSE	
21	290017	1	VAC MOTOR GASKET	
22	361218	1	CABLE TIE, BLACK	
23	450040	2	FITTING-90 3/8MPT X 3/8BARB NYLON	
24	450092	1	CRIMP CLAMP 27/64" TO 17/32"	
25	452037	2	CLAMP-CRIMP 170R SS	
26	710530	2	SCR-MC FL HD 8-32 X .50 BRS	
27	711118	1	SCR-ST-A 10 X .75 SS	
28	711504	4	WSR-FLAT 1/4 ID SS	
29	711524	6	WSR-WAVE .52 X .87 X .01	
30	711534	2	WSR-EXTERNAL LOCK #10	
31	711575	3	WSR-FLT .31x.75x.06ST	
32	711577	3	WSR-FLAT 260 X .50 X .020THK	
33	711594	10	WSR-FLAT .56 X .88 X .03	
34	711713	2	RETAINING RING - "E" TYPE EXT .500	
35	712070	3	BLT-SHOULDER 5/16 X 3/4 X 1/4-	
36	712150	2	SC-BHCS, 10-24 X .50 SS	
37	712536	2	SCR-MC 10-24 X .62 TH SS	
38	712562	4	BOLT-HH 1/4-20X3/4 SS	
39	712758	4	WSR-HELICAL 1/4 SS	
40	712764	2	WSR #10 SS	
41	712772	3	WSR-FLAT .344 x .75 x .06 SS	
42	715724	2	Decal X17	
43	740089-1	1	VAC MOTOR ASY, 115V	115V MODELS ONLY
43A	740260-1	1	VAC MOTOR ASY, 240V W/RF CHOKE	230V MODELS ONLY
44	817306	3	SCR-MC PAN HD M6x16 ZY	
45	828952	1	FITTING PP 1/4" MPT X 3/8" HOSE BARB	
46	553530122	3	CLAMP VACUUM MOTOR ASSEMBLY	
47	553530123	3	GROMMET, VACUUM MOTOR	
48	715914W	1	DECAL, MINUTEMAN W/SWOOSHES, WHITE	

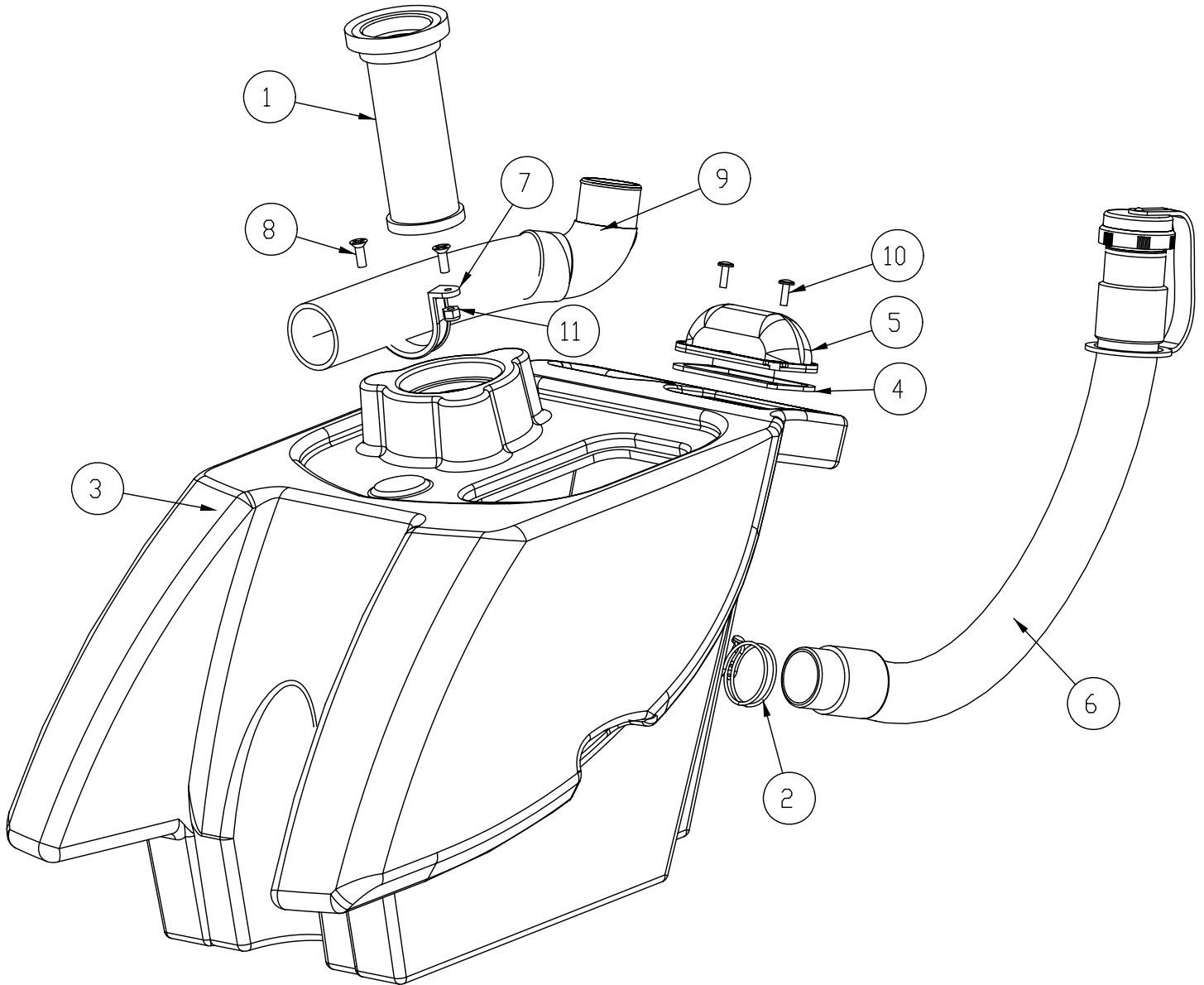

Recovery Tank Assembly BOM

BILL OF MATERIAL - 173020				
ITEM	PART NO.	REQ'D	DESCRIPTION	NOTES
1	172132	1	SCREENED FLOAT	
2	172329	1	CLAMP-HOSE 1.56" 102122 MURRAY	
3	173002	1	RECOVERY TANK EX17-ECO	
4	173025	1	RECOVERY WINDOW GASKET	
5	173026	1	RECOVERY WINDOW	
6	173063	1	HOSE, DUMP	
7	173099	1	PLASTIC TWO-HOLE STRAP	
8	173100	2	SCR FL HD 1/4-20 x 3/4 SS	
9	173104	1	HOSE, RECOVERY 12.5"	
10	712536	2	SCR-MC 10-24 X .62 TH SS	
11	712667	2	NUT, HEX 1/4-20 NYLOC SS	
12	173030	3	SCR THUMB, 10-24 X 3/8 IN	NOT SHOWN - USED BEFORE 08/2011 S/N: 11080345
13	173031	1	RETAINER, SCREENED FLOAT	NOT SHOWN - USED BEFORE 08/2011 S/N: 11080345
14	173071	1	FILTER, SCREENED FLOAT	NOT SHOWN - USED BEFORE 08/2011 S/N: 11080345

Recovery Dome Lid Assembly

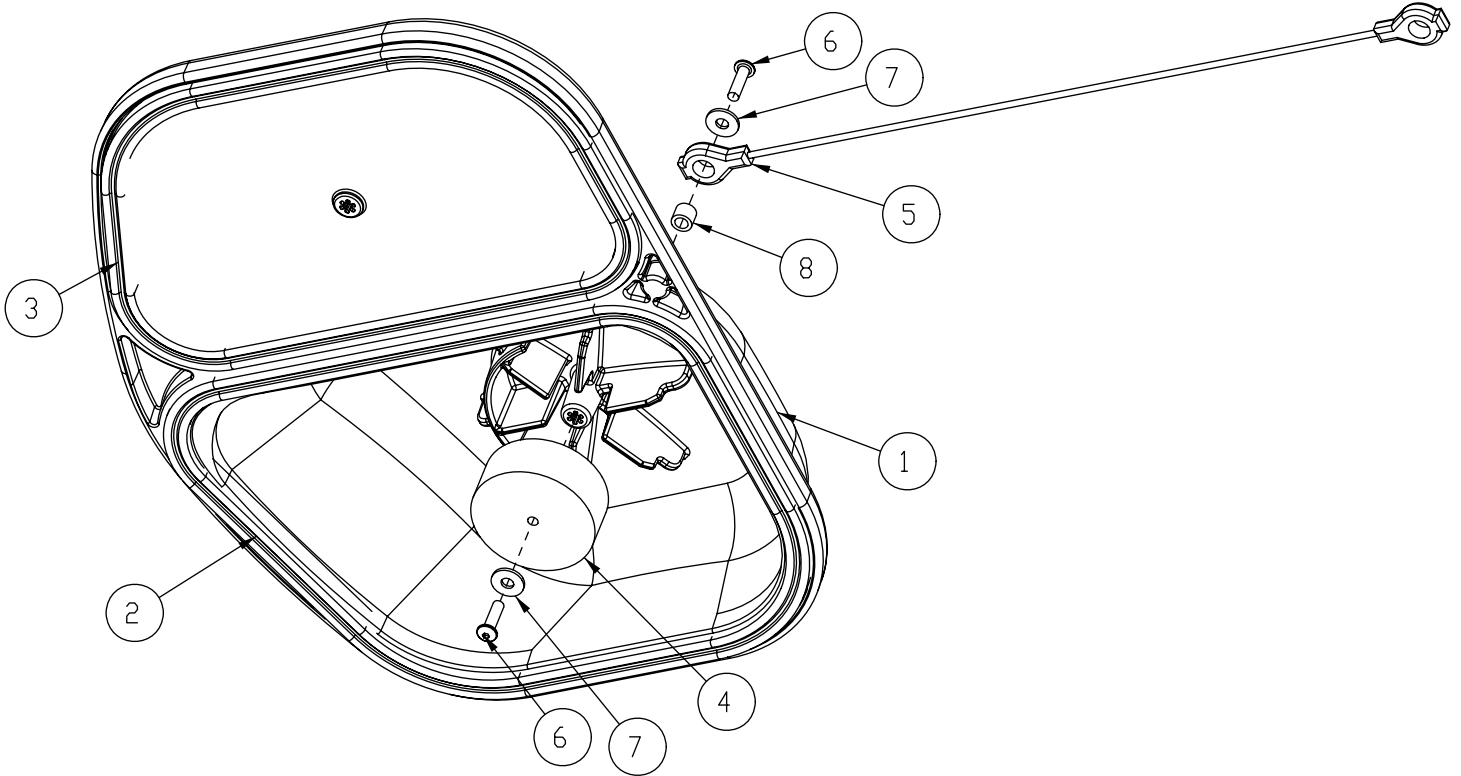

BILL OF MATERIAL - 173195			
ITEM	PART NO.	REQ'D	DESCRIPTION
1	173175	1	RECOVERY DOME LID
2	173177	1	GASKET, X17 LID, RT
3	173178	1	GASKET, X17 LID, LFT
4	173186	1	FILTER, X17 DOME LID
5	173187	1	CABLE 12.0
6	712516	2	SCR-BHCS #8-32 x .62 SS
7	712764	2	WSR #10 SS
8	762410	1	BUSHING, .2 X .31 X .265 ALUM

Spray Bar Assembly, X17

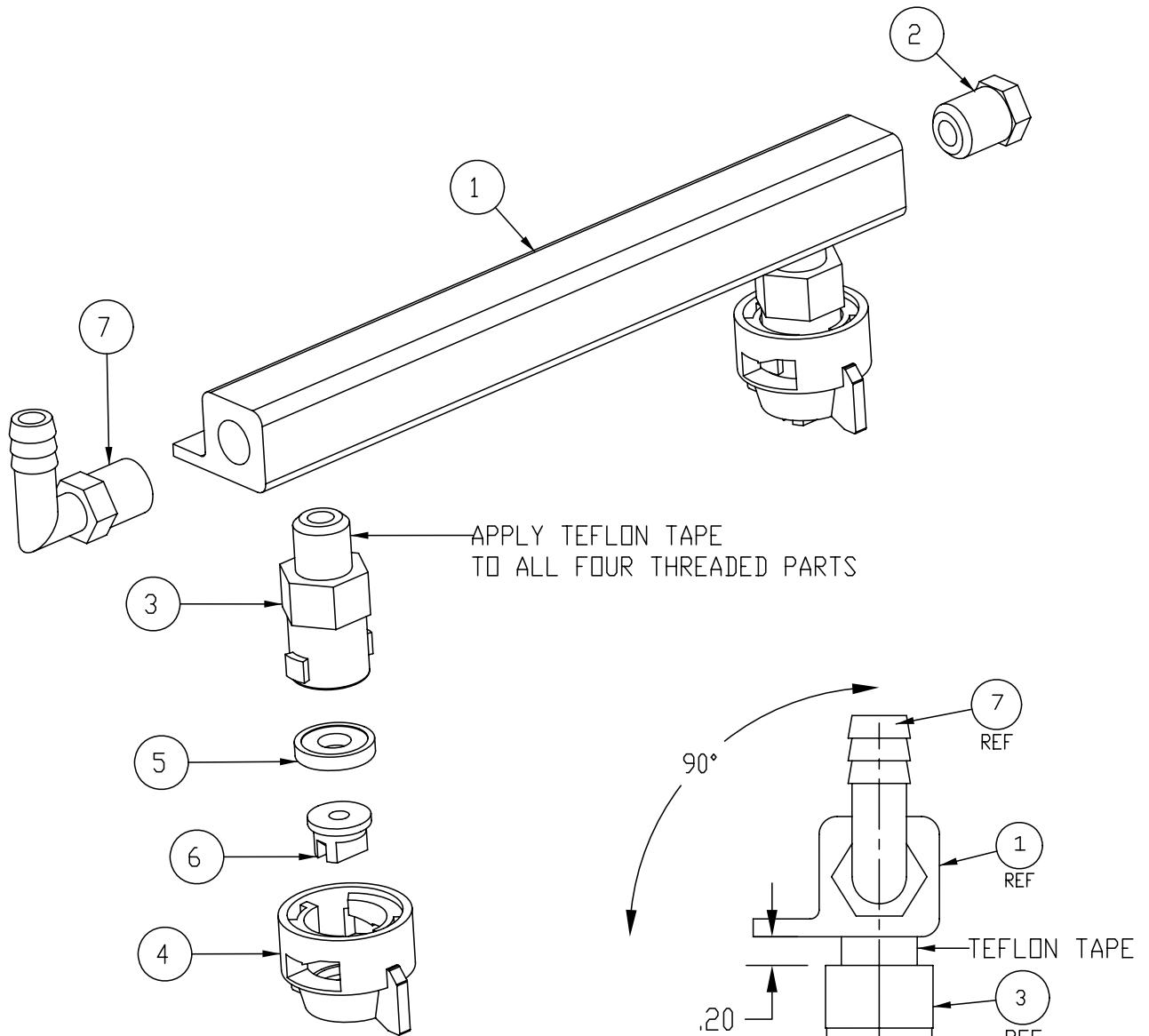

ORIENT FITTING (PN 833325) AND INLET CONNECTOR (833140) AS SHOWN (2X)

BILL OF MATERIAL - 173033 / 173033HP			
ITEM	PART NO.	REQ'D	DESCRIPTION
1	173041	1	SPRAY BAR
2	829619	1	END PLUG
3	833140	2	BODY INLET CONNECTOR
4	833141	2	CAP
5	833142	2	GASKET CAP
6	833144	2	SPRAY TIP 9505 50PSI
6A	833144HP	2	SPRAY TIP 9505 100PSI
7	833325	1	FITTING NYLON 90 1/4MPT X 3/8HB

X17 ECO Handle Assembly

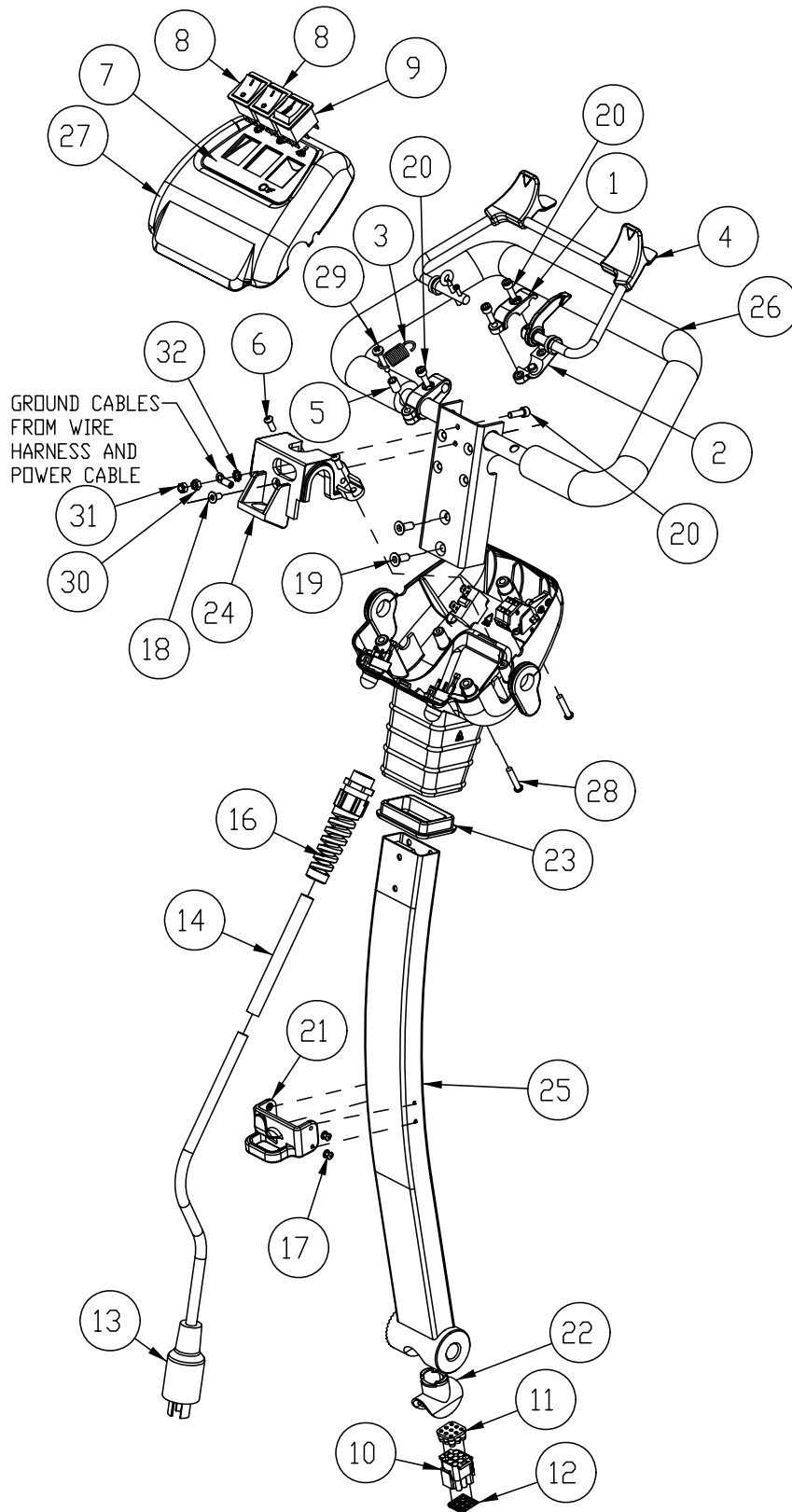

X17 ECO Handle Assembly BOM

BILL OF MATERIAL - 173200 (115V) / 173201 (230V)				
ITEM	PART NO.	REQ'D	DESCRIPTION	NOTES
1	173162	2	TOP BRACKET -MOMENTARY HANDLE	
2	173163	2	BOTTOM BRACKET - MOMENTARY HANDLE	
3	173203	1	SPRING-EXT 1.375 FL X .5 OD ZP	
4	173215	1	MOMENTARY HANDLE ASM	AFTER 08/2011 S/N: 11080188
	173137	1	MOMENTARY HANDLE ASM	NLA - REPLACE WITH K-HANDLESWITCH
5	255045	1	SPACER, .196X.31X.47 ALUM	
6	711163	2	SCR-HI/LO #10-16 X 1/2	
7	715722	1	DECAL, DASHBOARD EX17	
8	748602	2	SWITCH, DPST ON-OFF IP55	
9	748603	1	SWITCH, DPDT ON-OFF-ON IP55	
10	748605	1	CONNECTOR, 9P MALE	
11	748608	1	SEAL 9P MALE WIRE	
12	748609	1	SEAL, 9P INTERFACE	
13	748614-1	1	CORD, PIGTAIL ASM X17 115V	115V MODELS ONLY
13A	748614CE-1	1	CORD, PIGTAIL ASM X17 230V	230V MODELS ONLY
14	748649	1	TUBING, VINYL COATED 4.5"	
15	748700	1	WIRE HARNESS, HANDLE ASM - UL	
16	748701	1	CABLE GLAND WITH SPIRAL GUARDS PG16	
17	827666	4	RIVET-POP	
18	829203	1	SCR-SC FH M5X10 SS	
19	829306	2	SCR-SC FH M6X16 SS	
20	831206	4	SCR-SC M5X16 ZP	
21	931177	1	RETAINER, CORD	
22	931182	1	BOOT, HANDLE LOWER	
23	931199	1	PLUG - HANDLE COVER	
24	3130072	1	BRACKET-CHANNEL	
25	3180016	1	HANDLE ARM (WELDMENT)	
26	3180029	1	STEERING ASM	
27	3180120	1	SWITCH COVER TOP - X17	
28	3402036	3	SCR-HI/LO #10-16 X 1"	
29	11175494	1	SCR-MC M5 X 25 SS DIN7985	
30	12022430	1	NUT - HEX, M5, SS DIN934	
31	12040036	1	NUT-NYLOC M5 X 0.8	
32	12518080	1	EXTERNAL TOOTHED WASHER - M5	

X17 ECO Handle Assembly Breakout

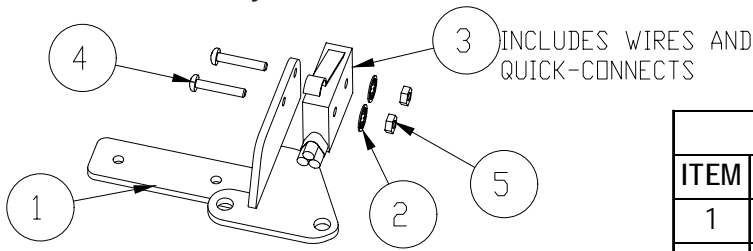

BILL OF MATERIAL - 173214			
ITEM	PART NO.	REQ'D	DESCRIPTION
1	173185	1	BKT, LIMIT SWITCH MOUNT
2	712326	2	WSR-INT LOCK #4
3	748611-1	1	SWITCH ASY, MICROSWITCH W/QC
4	818719	2	SCR-MC PAN HD M2 X 12 ZP
5	823101	2	NUT-HEX M2X0.4 ZP

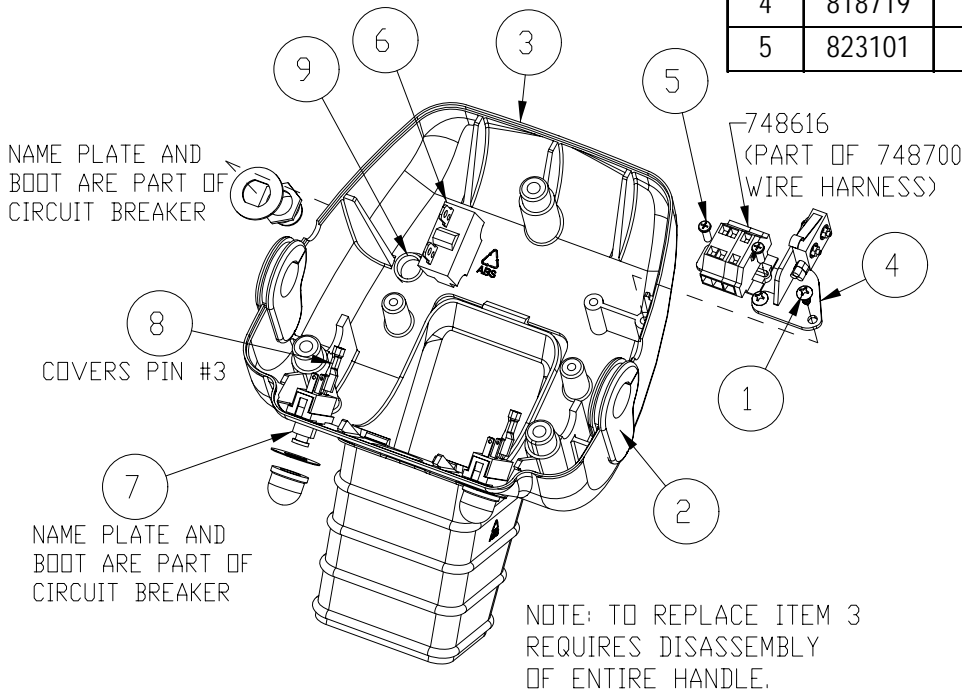

BILL OF MATERIAL - 173200 / 173201 cont'd.				
ITEM	PART NO.	REQ'D	DESCRIPTION	NOTES
1	173064	2	SCR-ST PAN HD #6 x 3/8" SS	
2	173161	2	GROMMET, HANDLE COVER	
3	173210	1	COVER, HANDLE BOTTOM ASM	
4	173214	1	LIMIT SWITCH ASSEMBLY, X17 HNDLE	
5	711686	2	SCR-MC M3 X 10 ZP	
6	748620	1	CIRCUIT BREAKER, 12A SMALL	115V MODELS ONLY
6A	748672	1	CIRCUIT BREAKER 7A SMALL 125-25	230V MODELS ONLY
7	748695	2	CIRCUIT BREAKER, 1.5A 1410	AFTER 08/2011 S/N: 11080188
	748621	1	CIRCUIT BREAKER, 4A (SPRAY PUMP)	BEFORE 08/2011 S/N: 11080188
	748622	1	CIRCUIT BREAKER, 3A (BRUSH MOTOR)	BEFORE 08/2011 S/N: 11080188
	748696	2	CIRCUIT BREAKER, 1A 1410	AFTER 08/2011 S/N: 11090395

Back Panel Assembly

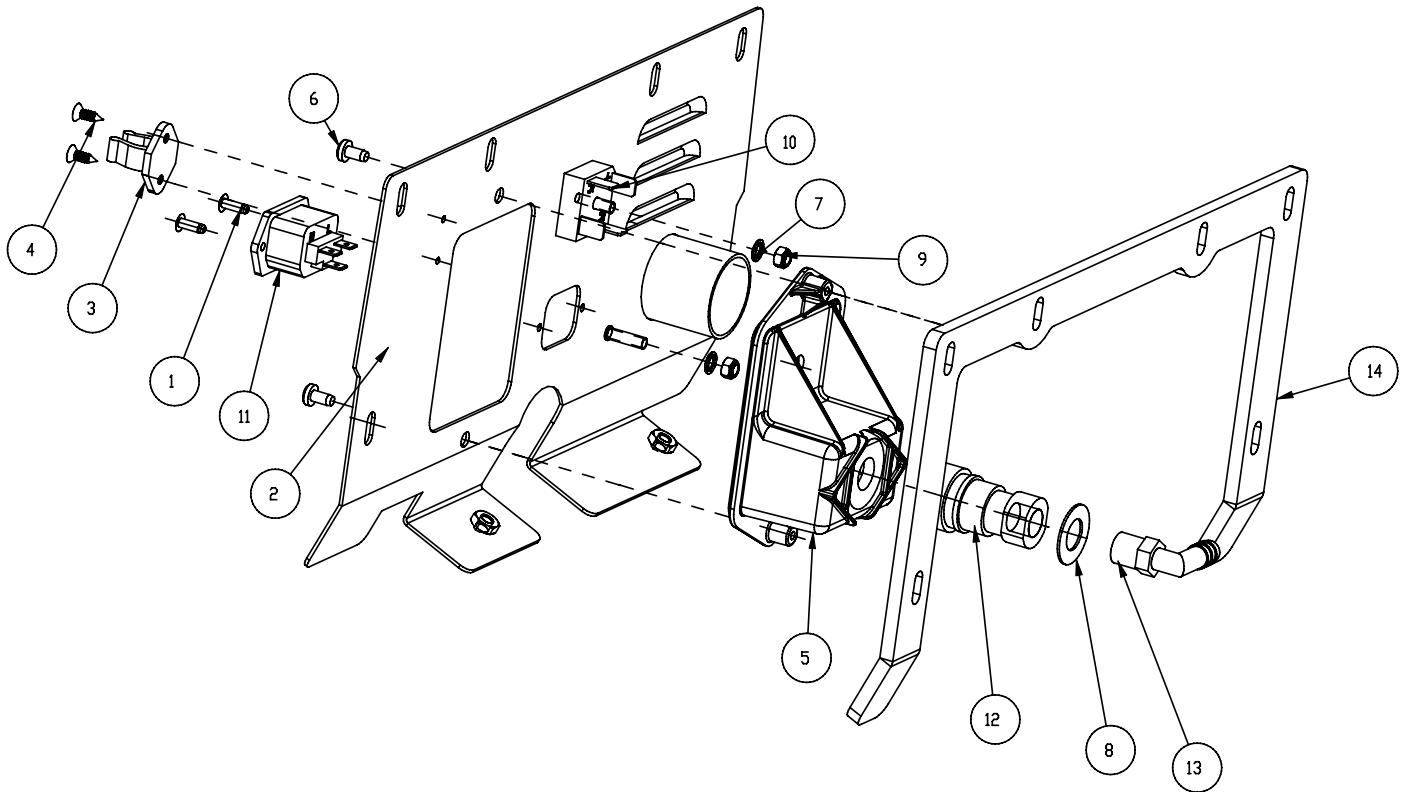

BILL OF MATERIAL - 173043			
ITEM	PART NO.	REQ'D	DESCRIPTION
1	410-4419AA	2	RIVET-POP
2	173034	1	BACK PANEL WELDMENT
3	173048	1	CLIP, 1/2 - 3/8 IN HOSE
4	173098	2	SCR-ST FL HD 8 X 1/2" STL ZINC
5	173107	1	AUX-CONTROL PANEL
6	711124	2	SCR-ST-B 10 X .37 NI
7	711553	2	WSR-INT LOCK #10
8	712760	1	WSR-FLT .56 X 1.06 X .04 SS
9	717017	2	NUT-NYLOC M5 X .08
10	740202	1	RECTIFIER-BRIDGE 50A 600V IMP
11	741038	1	RECEPTACLE-10A 250VAC IEC 320
12	828370	1	COUPLER-FEMALE BH2-60
13	833325	1	FITTING NYLON 90 1/4MPT 3/8HOS
14	171369	1	GASKET, BACK PANEL

Chassis Sub-Assembly X17-ECO

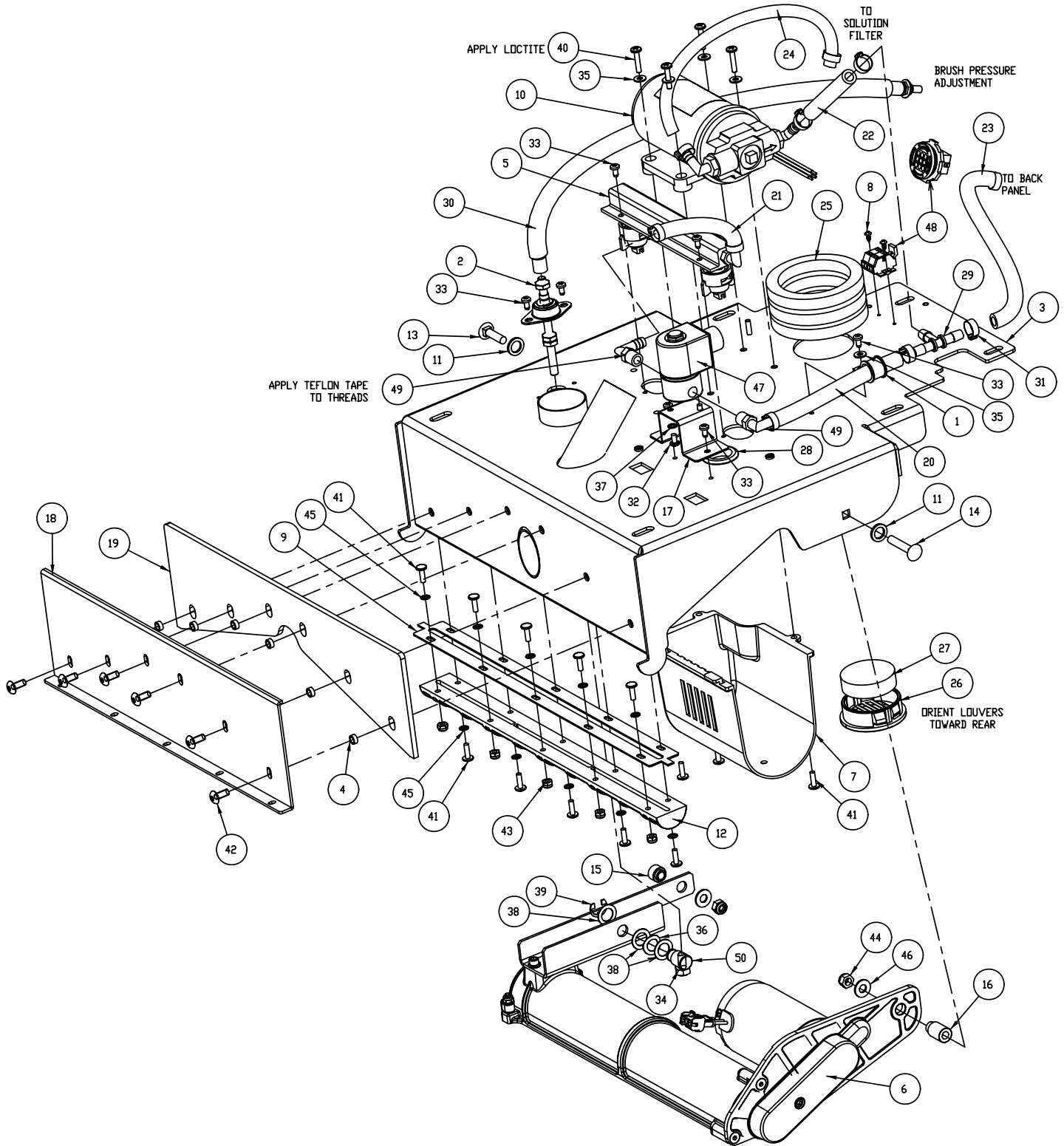

Chassis Sub-Assembly X17-ECO BOM

BILL OF MATERIAL - 173050 / 173050-230 / 173050HP / 173050-230HP				
ITEM	PART NO.	REQ'D	DESCRIPTION	NOTES
1	82-54-A	1	CLAMP, MS21333-114	
2	7545-10	1	FLANGED BEARING ASSY	
3	173004	1	MAINFRAME WELDMENT	
4	173018	6	SPACER, FRONT PLATE	
5	173033	1	EX17 - SPRAY BAR ASSEMBLY	50PSI MODELS ONLY
5A	173033HP	1	EX17 - SPRAY BAR ASSEMBLY	100PSI MODELS ONLY
6	173052	1	EX17 ECO SINGLE BRUSH ASSEMBLY	115V MODELS ONLY
6A	173052-230	1	EX17 ECO SINGLE BRUSH ASSEMBLY	230V MODELS ONLY
7	173061	1	GUARD, BRUSH MOTOR	
8	173064	2	SCR-ST PAN HD #6 x 3/8" SS	
9	173070	1	GASKET, VACUUM SHOE	
10	173076	1	PUMP ASY, 115V 50PSI EX17-ECO	X17115 ONLY
10A	173076-230	1	PUMP ASY, 230V 50PSI EX17-ECO	X17230 ONLY
10B	173076HP	1	PUMP ASY, 115V 100PSI EX17-ECO	X17115HP ONLY
10C	173076-230HP	1	PUMP ASY, 230V 100PSI EX17-ECO	X17230HP ONLY
11	173078	2	WSR FLT 1/2 x 3/4 x .09 SS	
12	173086	1	VACUUM SHOE, EX17 ECO	
13	173096	1	CARRIAGE SCREWS 5/16-18 X 1-1/4 SS	
14	173097	1	CARRIAGE SCREWS 5/16-18 X 1-3/4 SS	
15	173108	1	BUSH, SIDE ARM	
16	173109	1	BUSH, SIDE BRACKET	
17	173113	1	WATER VALVE BRACKET	
18	173120	1	FRONT SQUEEGEE PLATE	
19	173146	1	FRONT PLATE NEOPRENE GASKET X17	
20	173147	1	HOSE, 3/8 I.D x 7 IN	
21	173148	1	HOSE, SPRAY BAR, 3/8 ID x 5.5 IN	
22	173149	1	HOSE, PUMP 3/8 I.D x 4.5 IN	
23	173150	1	HOSE, COUPLER 3/8 I.D x 12 IN	
24	173151	1	HOSE, 3/8 ID x 17 IN	
25	173171	3	FELT 3 x 4 x .5	
26	173172	1	LOUVERED PLUGS	
27	173173	1	FILTER, SCREENED FLOAT	
28	220327	1	GROMMET 1.25 X 1 X .125	
29	241726	1	NYLON SINGLE-BARBED TEE, 3/8"	
30	452010	1	#160 2BLT FLG BRG W3/8B	
31	452037	10	CLAMP-CRIMP 170R SS	
32	710353	2	SCR-MC RD HD 10-32 X .37 STL	
33	711124	7	PAN HEAD ST #10 X .37 NI	
34	711383	1	NUT-HEX CLR LOC 5/16-18	
35	711503	5	WSR, FLAT #10	
36	711524	1	WSR-WAVE .52 X .87 X .01	
37	711553	2	WSR- INTERNAL LOCK #10	
38	711594	3	WSR-FLAT .56 X .88 X .03	
39	711713	1	RETAINING RING - "E" TYPE EXT .500	
40	712532	4	SCR - MC, PAN HD, 10-24 X 1.00, SS	
41	712536	13	SCR-MC 10-24 X .62 TH SS	
42	712559	6	SCR-TR 1/4-20 X .62 TORX TR HD	
43	712638	5	NUT, HEX 10-24 SS NYLOC	
44	712683	2	NUT, HEX 5/16-18 NYLOC SS	
45	712770	10	WSR INT LOCK #10A SS	
46	712772	2	WSR-FLAT .344 x .75 x .06 SS	
47	740492-1	1	VALVE ASY, SOLENOID 115V X17	
48	748650	1	WIRE HARNESS, BASE ASM X17 115V	115V MODELS ONLY
48A	748650-230	1	WIRE HARNESS, BASE ASM X17 230V	230V MODELS ONLY

Brush Head Assembly ECO

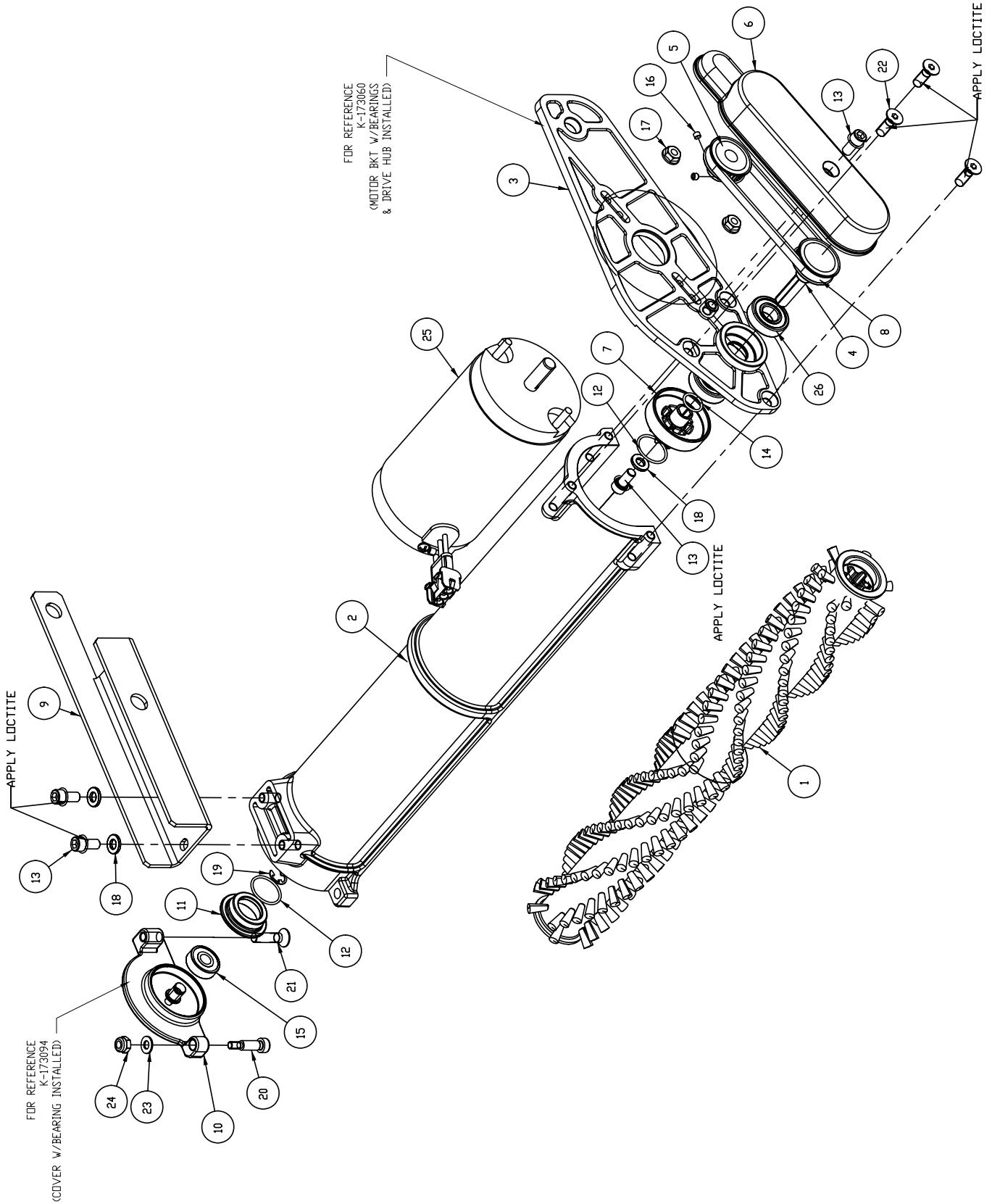

Brush Head Assembly ECO BOM

BILL OF MATERIAL - 173052 / 173052-230				
ITEM	PART NO.	REQ'D	DESCRIPTION	NOTES
1	173055	1	EX17 BRUSH CORE ASSEMBLY	
2	173056	1	BRUSH BASE	
3	173060	1	MOTOR BRACKET	
4	173062	1	SPROCKET 30	
5	173065	1	DRIVE SPROCKET ASSEMBLY	
6	173066	1	COVER BELT	
7	173067	1	DRIVE PULLEY	
8	173068	1	BELT	
9	173075	1	LIFT BRACKET	
10	173094	1	BRUSH SIDE COVER	
11	173095	1	IDLE PULLEY	
12	173115	2	O-RING 20mm x 1.5mm	
13	173145	4	SC - SHCS 1/4"-20 X 0.5 SS	
14	173176	1	O-RING 12mm x 1.5mm	
15	173208	1	BEARING-DBL SEALED 8X22X7	
16	711001	2	SK 8-32 X .12	
17	711427	2	NUT-FLANGED WIZZ 10-32	
18	711566	3	WSR-FLAT .259 X .500 X .065	
19	711721	1	RET RING-E TYPE .312	
20	712151	1	BLT SHOULDER, 10-24 x 5/8 IN	
21	712153	1	SC-SHCS, 1/4-20 x 1.00 IN SS	
22	712154	3	SC-SHCS, 1/4-20 x 0.75, SS	
23	712320	1	WSR-NYLON .22 X .45 X .04	
24	712638	1	NUT, HEX 10-24 SS NYLOC	
25	831238-2	1	BRUSH DRIVE MOTOR ASSEMBLY	115V MODELS ONLY
25A	832611-2	1	MOTOR BRUSH 230V	230V MODELS ONLY
26	875009	2	Bearing 12mm X 28mm Double Sealed	

Valve-Filter Assembly, X17

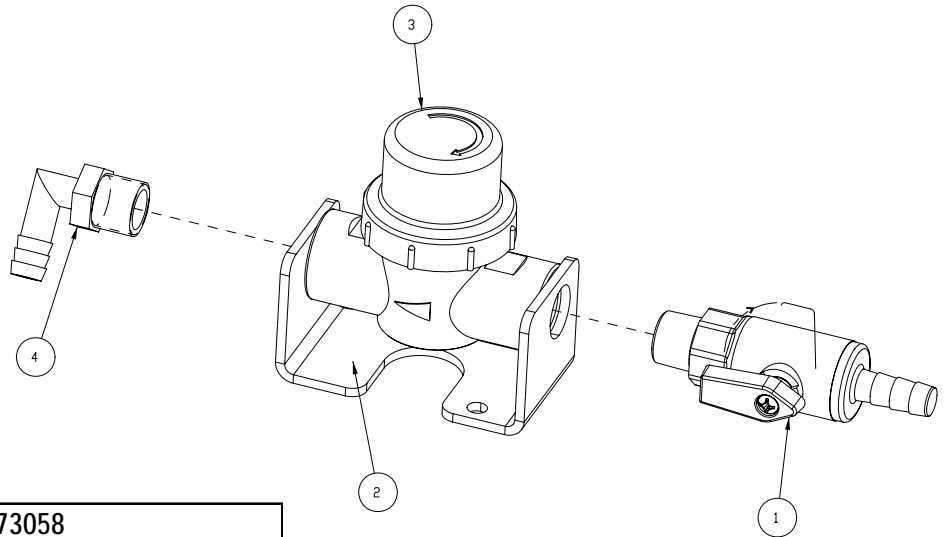

BILL OF MATERIAL - 173058			
ITEM	PART NO.	REQ'D	DESCRIPTION
1	173154	1	SHUT OFF VALVE, 3/8 BARB x 3/8 MPT
2	173155	1	BRACKET
3	173158	1	IN-LINE FILTER ASSEMBLY, 3/8 FNPT
4	450040	1	FITTING-90 3/8MPT X 3/8BARB NYLON

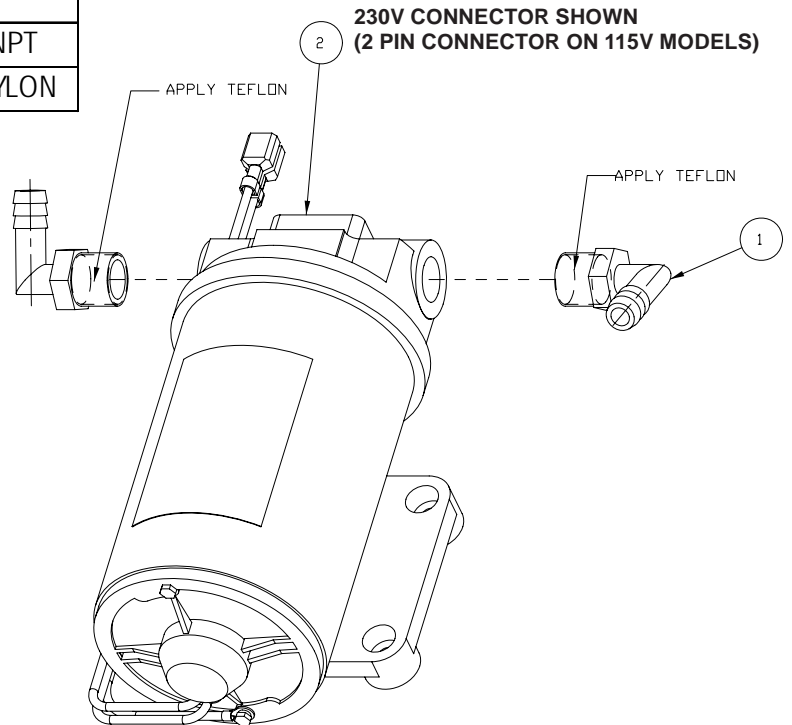

BILL OF MATERIAL - 173076 / 173076-230 / 173076HP / 173076-230HP				
ITEM	PART NO.	REQ'D	DESCRIPTION	NOTES
1	450040	2	FITTING-90 3/8MPT X 3/8BARB NYLON	
2	829757-1	1	PUMP ASY, BYPASS 115V 50PSI	X17115 MODEL ONLY
2A	742150-1	1	PUMP ASY, BYPASS 230V 50PSI	X17230 MODEL ONLY
2B	829757-1HP	1	PUMP ASY, BYPASS 115V 100PSI	X17115HP MODEL ONLY
2C	742150-1HP	1	PUMP ASY, BYPASS 230V 100PSI	X17230HP MODEL ONLY

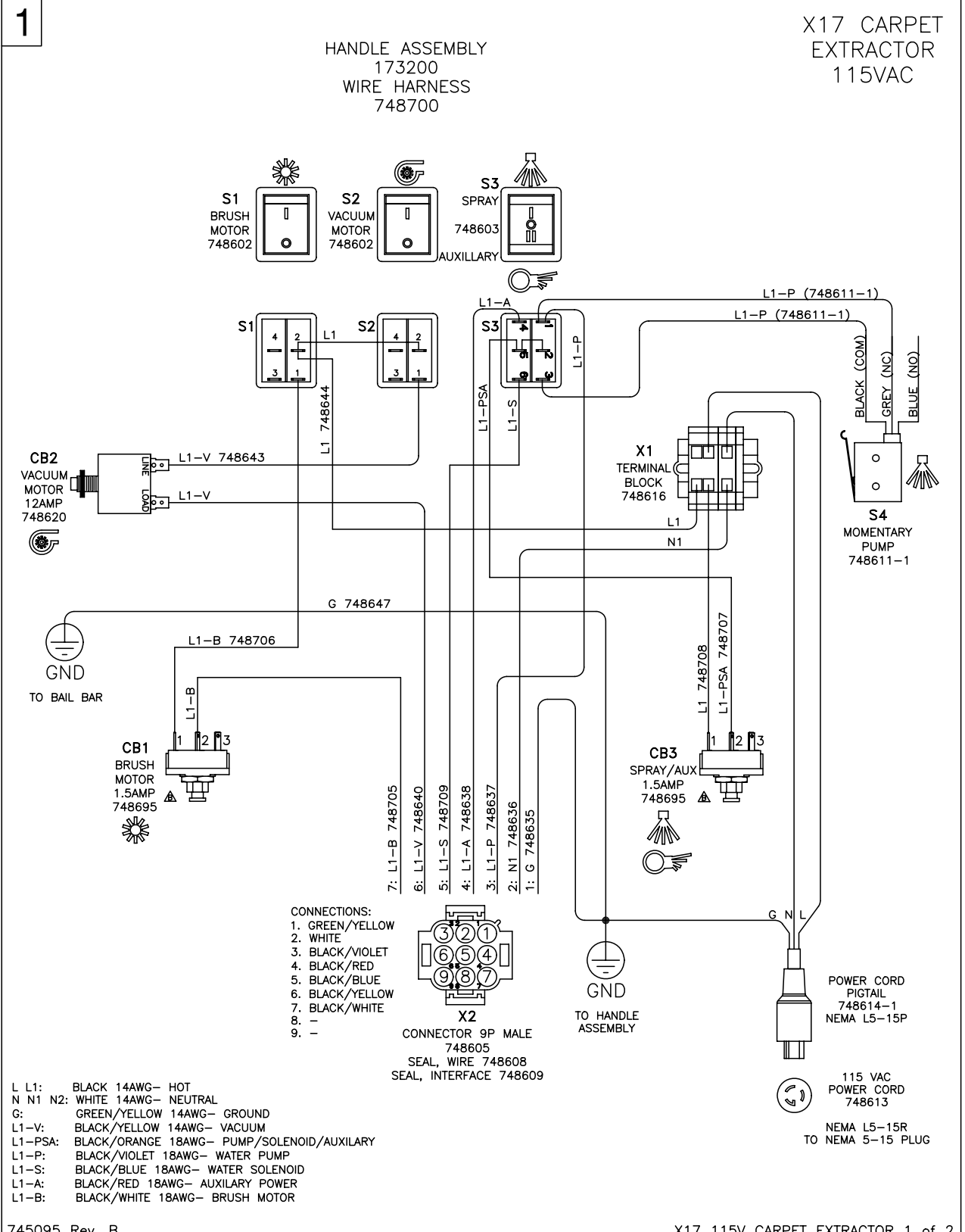

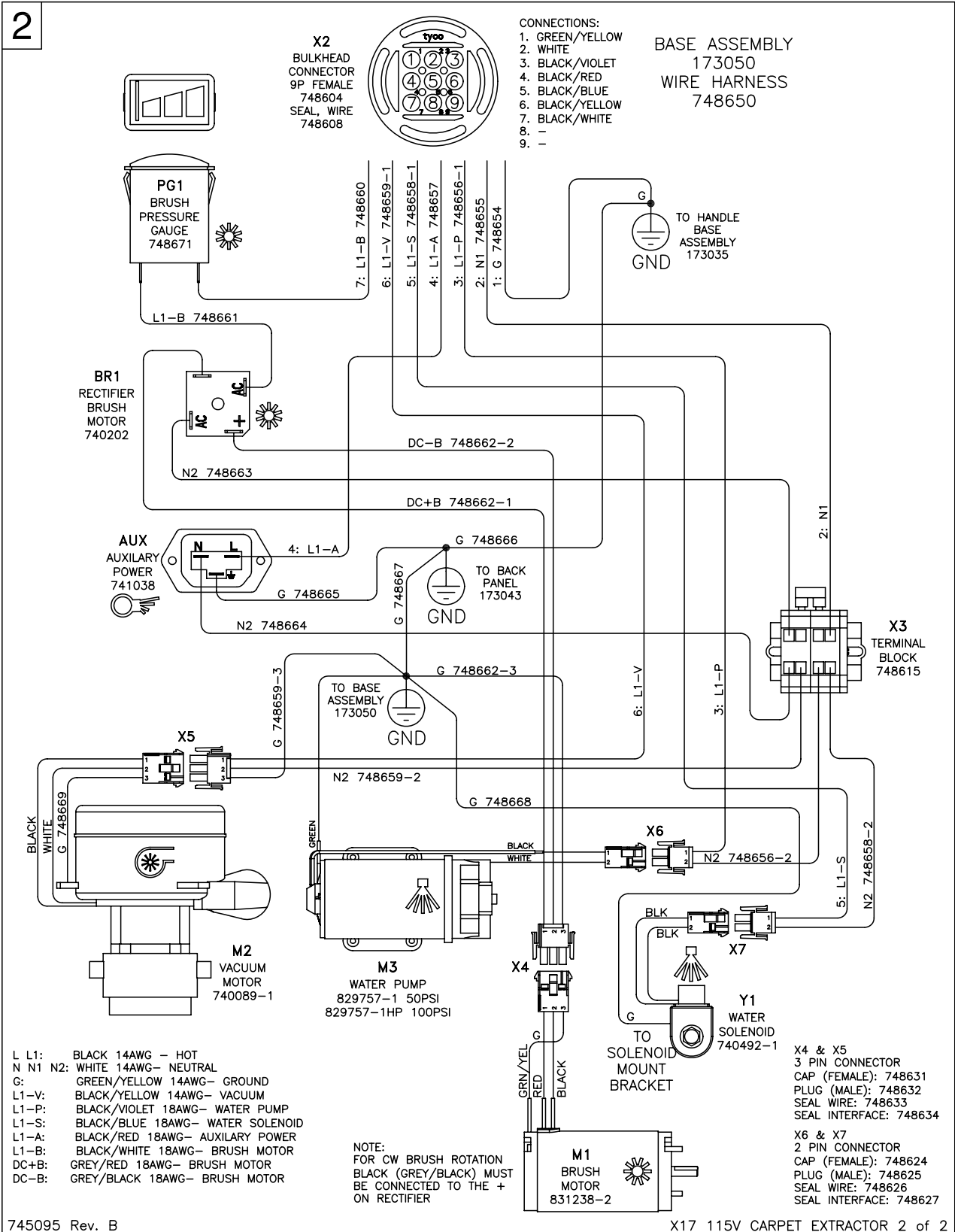

115V Models

X17-ECO 115V Electrical Schematic Reference Numbers

Reference #	Description	Part Number
S1	SWITCH, BRUSH MOTOR	748602
S2	SWITCH, VACUUM MOTOR	748602
S3	SWITCH, SPRAY & AUXILIARY	748603
S4	SWITCH, MICRO MOMENTARY PUMP	748611-1
CB1	CIRCUIT BREAKER, 1.5A BRUSH MOTOR	748695
CB2	CIRCUIT BREAKER, 12A VACUUM MOTOR	748620
CB3	CIRCUIT BREAKER, 1.5A PUMP/SOLENOID & AUXILIARY	748695
M1	MOTOR, BRUSH	831238-2
M2	MOTOR, VACUUM	740089-1
M3	PUMP, WATER 50 PSI	829757-1
M3	OPTIONAL: PUMP, WATER 100 PSI	829757-1HP
Y1	SOLENOID, WATER	740492-1
PG1	GAUGE, BRUSH PRESSURE	748671
BR1	RECTIFIER, BRUSH MOTOR	740202
AUX	RECEPTACLE, AUXILIARY POWER	741038
X1	TERMINAL BLOCK, HANDLE ASSEMBLY	748616
X2	CONNECTOR, 9 PIN BULKHEAD (FEMALE)	748604
part of X2	CONNECTOR, 9 PIN PLUG (MALE)	748605
part of X2	SEAL, WIRES 9 PIN	748608
part of X2	SEAL, INTERFACE 9 PIN	748609
X3	TERMINAL BLOCK, BASE ASSEMBLY	748615
X4 & X5	CONNECTOR, 3 PIN CAP (FEMALE)	748631
part of X4 & X5	CONNECTOR, 3 PIN PLUG (MALE)	748632
part of X4 & X5	SEAL, WIRES 3P	748633
part of X4 & X5	SEAL, INTERFACE 3 PIN	748634
X6 & X7	CONNECTOR, 2 PIN CAP (FEMALE)	748624
part of X6 & X7	CONNECTOR, 2 PIN PLUG (MALE)	748625
part of X6 & X7	SEAL, WIRES 2 PIN	748626
part of X6 & X7	SEAL, INTERFACE 2 PIN	748627

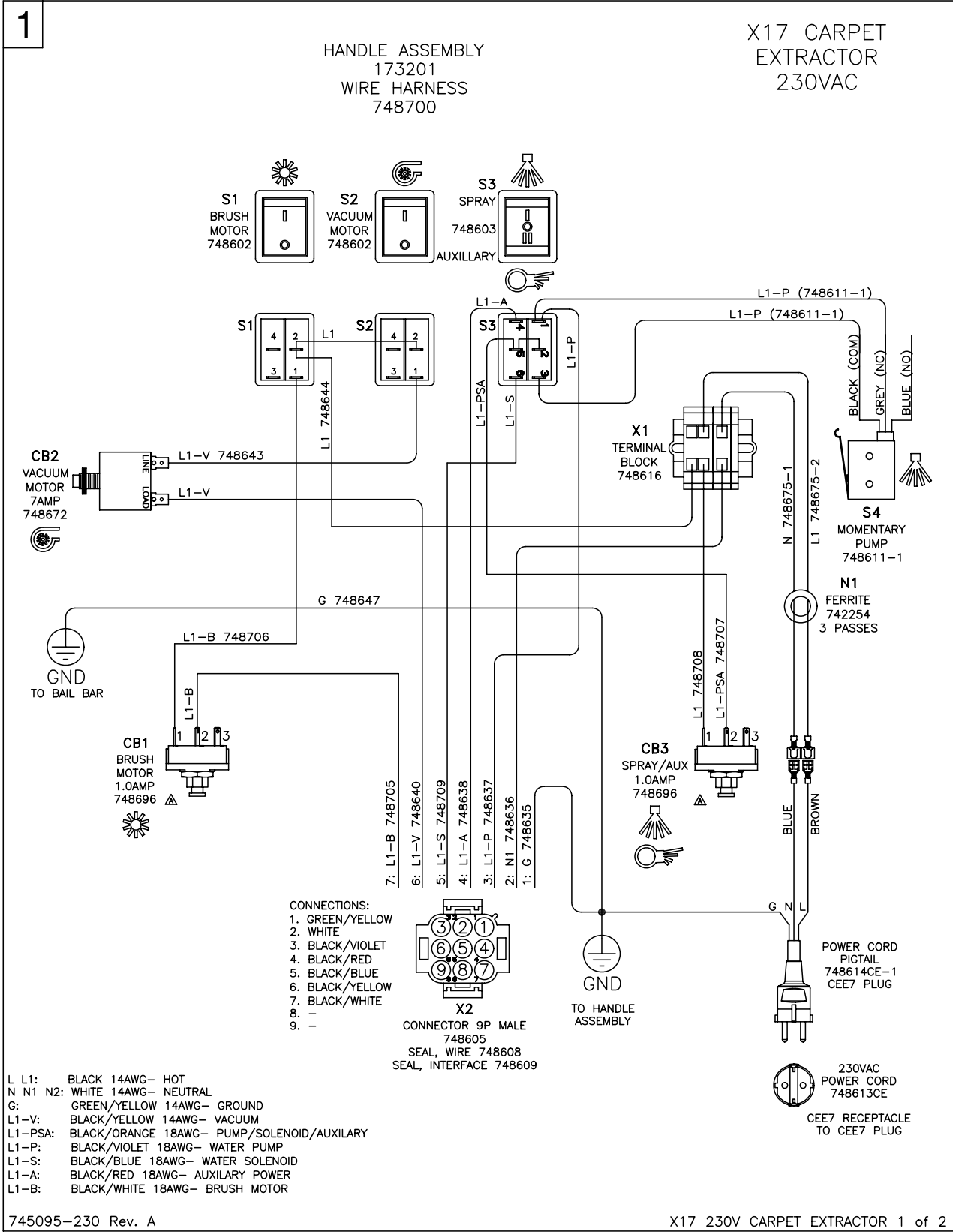

2

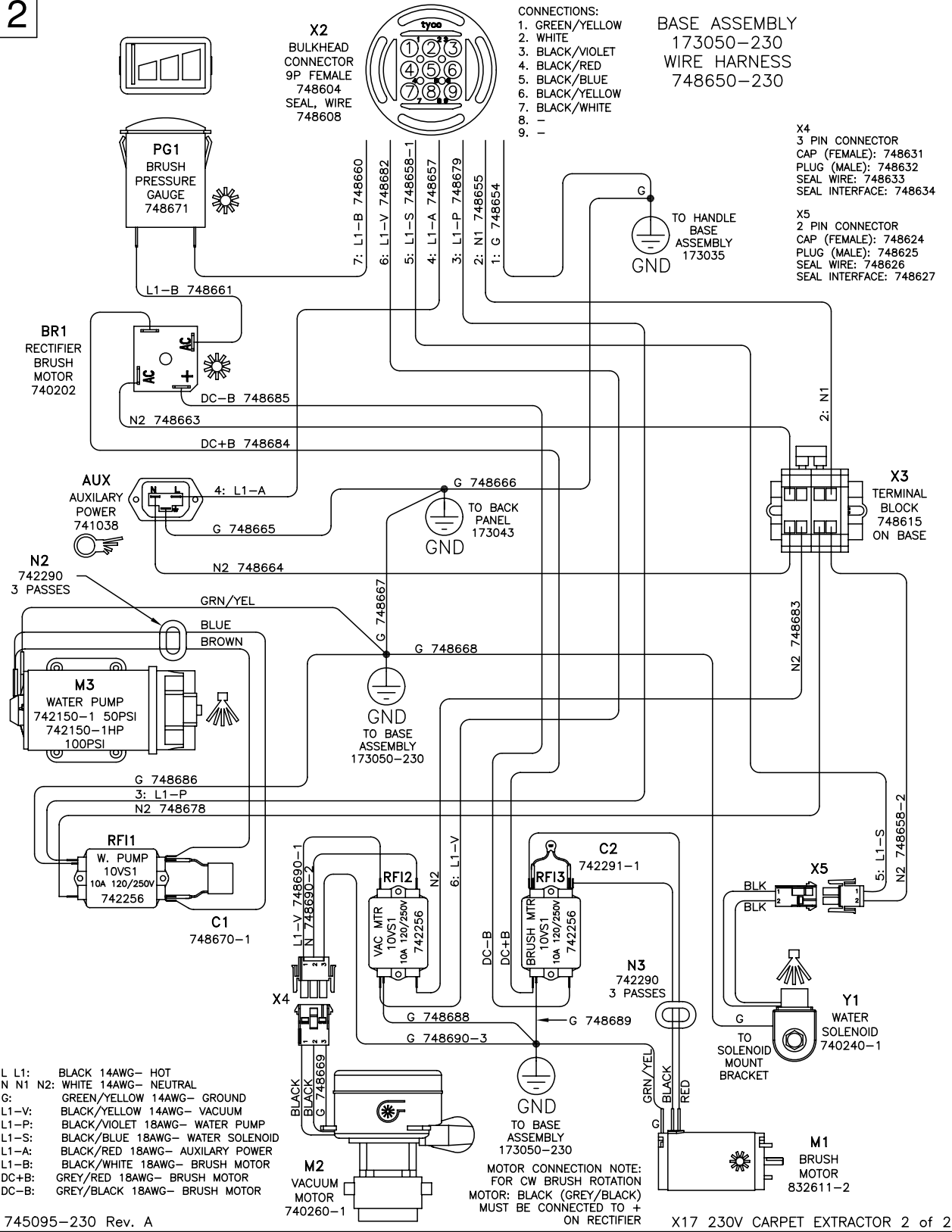

230V Models

X17-ECO 230V Electrical Schematic Reference Numbers

Reference #	Description	Part Number
S1	SWITCH, BRUSH MOTOR	748602
S2	SWITCH, VACUUM MOTOR	748602
S3	SWITCH, SPRAY & AUXILARY	748603
S4	SWITCH, MICRO MOMENTARY PUMP	748611-1
CB1	CIRCUIT BREAKER, 1.0A BRUSH MOTOR	748696
CB2	CIRCUIT BREAKER, 7A VACUUM MOTOR	748672
CB3	CIRCUIT BREAKER, 1.0A PUMP/SOLENOID & AUXILIARY	748696
M1	MOTOR, BRUSH	832611-2
M2	MOTOR, VACUUM	740260-1
M3	PUMP, WATER 50 PSI	742150-1
M3	OPTIONAL: PUMP, WATER 100 PSI	742150-2
Y1	SOLENOID, WATER	740240-1
PG1	GAUGE, BRUSH PRESSURE 230VAC	748671
BR1	RECTIFIER, BRUSH MOTOR	740202
AUX	RECEPTACLE, AUXILIARY POWER	741038
RFI1	RFI FILTER, WATER PUMP	742256
RFI2	RFI FILTER, VACUUM MOTOR	742256
RFI3	RFI FILTER, BRUSH MOTOR	742256
C1	CAPACITOR ASM, 1uF WATER PUMP	748670-1
C2	CAPACITOR ASM, 330pF BRUSH MOTOR	742291-1
N1	FERRITE, LINE	742254
N2	FERRITE, WATER PUMP	742290
N3	FERRITE, BRUSH MOTOR	742290
X1	TERMINAL BLOCK, HANDLE ASSEMBLY	748616
X2	CONNECTOR, 9 PIN BULKHEAD (FEMALE)	748604
part of X2	CONNECTOR, 9 PIN PLUG (MALE)	748605
part of X2	SEAL, WIRES 9 PIN	748608
part of X2	SEAL, INTERFACE 9 PIN	748609
X3	TERMINAL BLOCK, BASE ASSEMBLY	748615
X4	CONNECTOR, 3 PIN CAP (FEMALE)	748631
part of X4	CONNECTOR, 3 PIN PLUG (MALE)	748632
part of X4	SEAL, WIRES 3P	748633
part of X4	SEAL, INTERFACE 3 PIN	748634
X5	CONNECTOR, 2 PIN CAP (FEMALE)	748624
part of X5	CONNECTOR, 2 PIN PLUG (MALE)	748625
part of X5	SEAL, WIRES 2 PIN	748626
part of X5	SEAL, INTERFACE 2 PIN	748627

Minuteman International Made Simple Commercial Limited Warranty



REVISION F
EFFECTIVE 6/1/2009

Minuteman International, Inc. warrants to the original purchaser/user that the product is free from defects in workmanship and materials under normal use. Minuteman will, at its option, repair or replace without charge, parts that fail under normal use and service when operated and maintained in accordance with the applicable operation and instruction manuals. All warranty claims must be submitted through and approved by factory authorized repair stations.

This warranty does not apply to normal wear, or to items whose life is dependent on their use and care, such as belts, cords, switches, hoses, rubber parts, electrical motor components or adjustments. Parts manufactured by Minuteman are covered by and subject to the warranties and/or guarantees of their manufacturers. Please contact Minuteman for procedures in warranty claims against these manufacturers.

Special warning to purchaser — Use of replacement filters and/or prefilters not manufactured by Minuteman or its designated licensees, will void all warranties expressed or implied. A potential health hazard exists without original equipment replacement.

All warranted items become the sole property of Minuteman or its original manufacturer, whichever the case may be.

Minuteman disclaims any implied warranty, including the warranty of merchantability and the warranty of fitness for a particular purpose. Minuteman assumes no responsibility for any special, incidental or consequential damages.

This limited warranty is applicable only in the U.S.A. and Canada, and is extended only to the original user/purchaser of this product. Customers outside the U.S.A. and Canada should contact their local distributor for export warranty policies. Minuteman is not responsible for costs or repairs performed by persons other than those specifically authorized by Minuteman. This warranty does not apply to damage from transportation, alterations by unauthorized persons, misuse or abuse of the equipment, use of non-compatible chemicals, or damage to property, or loss of income due to malfunctions of the product.

If a difficulty develops with this machine, you should contact the dealer from whom it was purchased.

This warranty gives you specific legal rights, and you may have other rights which vary from state to state. Some states do not allow the exclusion or limitation of special, incidental or consequential damages, or limitations on how long an implied warranty lasts, so the above exclusions and limitations may not apply to you.

Cord Electric Group: Three years parts, two years labor, ninety days travel (Not to exceed two hours)

Exceptions.....

Model	Parts	Labor	Poly	Travel
Port A Scrub	1yr	6months	10yrs	0
MPV 13	1yr	0	0	0
MPV 14 & 18	2yrs	1yr	0	0
V Series Upright Vacuums	1yr	1yr	0	0
Rapid Air Blower	1yr	1yr	10yrs	0
Explosion Proof Vacuum	1yr	1yr	0	0
X12, X12H & TRS 14	1yr	1yr	10yrs	0
E17 & E20 Electric Scrubbers	1yr	6month	10yrs	0
Pneumatic Vacuums	3yr	1yr	0	0

Description	Parts	Labor	Poly	Travel
Battery Operated Group	3yrs	2yrs	10	90 days
Sweepers	1yr	1yr	10	90 days
Internal Combustion Group	1yr	1yr	10	90 days

Not to exceed two hours

Exception: PAS 14B **1yr** **1yr** **10yr** **0**

Battery Chargers:

Replacement Parts:

Batteries:

Polyethylene Plastic Tanks:

One year replacement

Ninety days

0-3 months replacement, 4-12 months pro-rate

Tanks have 10yr warranty, no additional labor